

COMPONENT DATASHEETS

TABLE OF CONTENTS



| | |
|-------------------------------|----------|
| 3 COMPONENT DATASHEETS | 2 |
| 3.1 POWER DISTRIBUTION BOARD | 2 |
| 3.1.1 Functional Description | 2 |
| 3.1.2 Pinout | 3 |
| 3.1.3 Typical Application | 5 |
| 3.1.4 Specifications | 6 |
| 3.1.5 Notes and Warnings | 7 |
| 3.1.6 Troubleshooting and FAQ | 7 |
| 3.1.7 Mechanicals | 10 |
| 3.2 COMPACT RIO | 11 |
| 3.3 ANALOG BREAKOUT | 11 |
| 3.3.1 Functional Description | 12 |
| 3.3.2 Typical Application | 13 |
| 3.3.3 Specifications | 13 |
| 3.3.4 Troubleshooting and FAQ | 13 |
| 3.3.5 Mechanicals | 15 |
| 3.4 DIGITAL SIDECAR | 16 |
| 3.4.1 Functional Description | 16 |
| 3.4.2 Typical Application | 19 |
| 3.4.3 Specifications | 19 |
| 3.4.4 Warnings | 21 |
| 3.4.5 Troubleshooting and FAQ | 21 |
| 3.4.6 Mechanicals | 22 |
| 3.5 SOLENOID BREAKOUT | 23 |
| 3.5.1 Functional Description | 24 |
| 3.5.2 Typical Application | 24 |
| 3.5.3 Specifications | 25 |
| 3.5.4 Troubleshooting and FAQ | 25 |
| 3.5.5 Mechanical | 26 |

3 COMPONENT DATASHEETS

This section of the FRC Control System Manual contains datasheets for all of the control system components manufactured specifically for the FIRST Robotics Competition.

3.1 POWER DISTRIBUTION BOARD



3.1.1 Functional Description

The PD Module is used to safely distribute battery power via thermal breakers and WAGO connectors. The PD also includes a set of power supplies for various devices.

- Battery input voltage range of 6-15V
- M6 shanks for battery connection
- Sufficient copper mass and low-resistance distribution for use with a 120A main breaker supplying the module
- 8 outputs that support up to 40A breakers
- 12 outputs that support up to 30A breakers
- 24V/1.5A boost supply with on-board 1.1A PTC for over-current protection (typically for powering a cRIO from National Instruments)
- 5V/3A buck supply with integral over-current protection (typically for powering an Ethernet camera)
- 12V/2A boost supply with on-board 2A PTC for over-current protection (typically for powering a WiFi adapter, the boost supply tracks battery voltage when the battery is fully charged and greater than 12V)
- Reverse battery protection for the cRIO, WiFi, and Camera power supplies
- LEDs for each power supply They light red if and only if there is a load present and either breaker is absent or the breaker is blown

3.1.2 Pinout

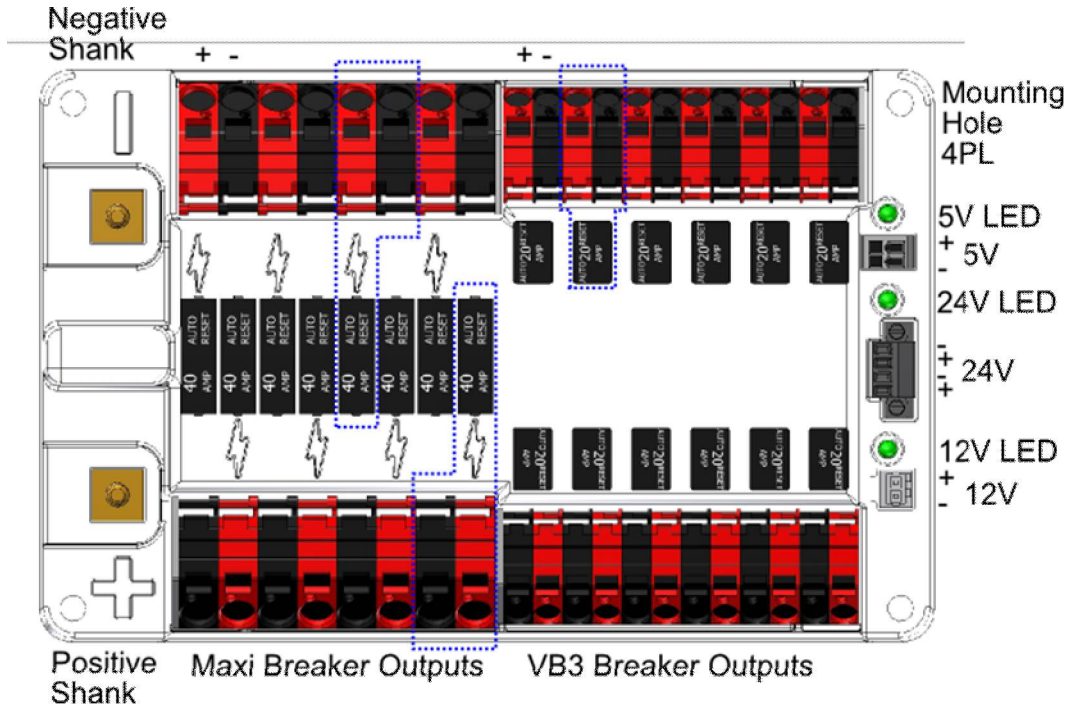

| PCB Reference Designator | Name | Description |
|--|------------------------|--|
| J27 | Negative Shank | M6 post for connecting the negative terminal of a battery |
| J23 | Positive Shank | M6 post for connecting the positive terminal of a battery (typically a 12V sealed lead acid battery through a 120A main breaker) |
| J1/J3, J4/J5, J6/J7, J8/J9, J29/J28, J31/J30, J33/J32, J35/J34 | Maxi Breaker Outputs | WAGO 745-85X connector pairs that provide battery positive (red terminals, protected via thermal breaker) and battery negative/return (black terminals) Accepts stranded wire 6-12 AWG stripped 12-13mm |
| J11-J22, J37-J48 | VB3 Breaker Outputs | WAGO 745-83X connector pairs that provide battery positive (red terminals, protected via thermal breaker) and battery negative/return (black terminals) Accepts stranded wire 10-24AWG stripped 11-12mm |
| CB7-CB14 | Maxi Breaker Terminals | Press-in terminals that accept Snap Action Maxi-Style breakers with capacity up to 40A |
| CB1-CB6, CB19-CB24 | VB3 Breaker Terminals | Press-in terminals that accept Snap Action VB3-Style breakers with capacity up to 30A |
| J26 | 5V Output | FRC control system usage: Axis camera. Output from a 5V/3A buck supply via WAGO 739-302 terminal strip. Accepts stranded wire 14-22 AWG stripped 7mm |
| J24 | 12V Output | FRC control system usage: Linksys WiFi adapter Output from a 12V/2A boost supply via WAGO 734-132 header. WAGO 734-102 is the typical mating connector with wire size between 14 and 22 AWG. |

| PCB Reference Designator | Name | Description |
|--------------------------|------------|--|
| J25 | 24V Output | <p>FRC control system usage: National Instruments cRIO</p> <p>Output from a 24V/1.5A boost supply via Sauro CTM040V8 connector. The mating connector is Sauro CTF04BV8-CN. The positive and negative terminals are duplicated on the 4-position header to mimic the input structure on the National Instruments cRIO power entry connector. Use wire size between 14 and 22 AWG.</p> |

3.1.3 Typical Application

** Always refer to FIRST rules for using this module in competition robots. The following diagram shows an example application that may not fully comply with FIRST rules.

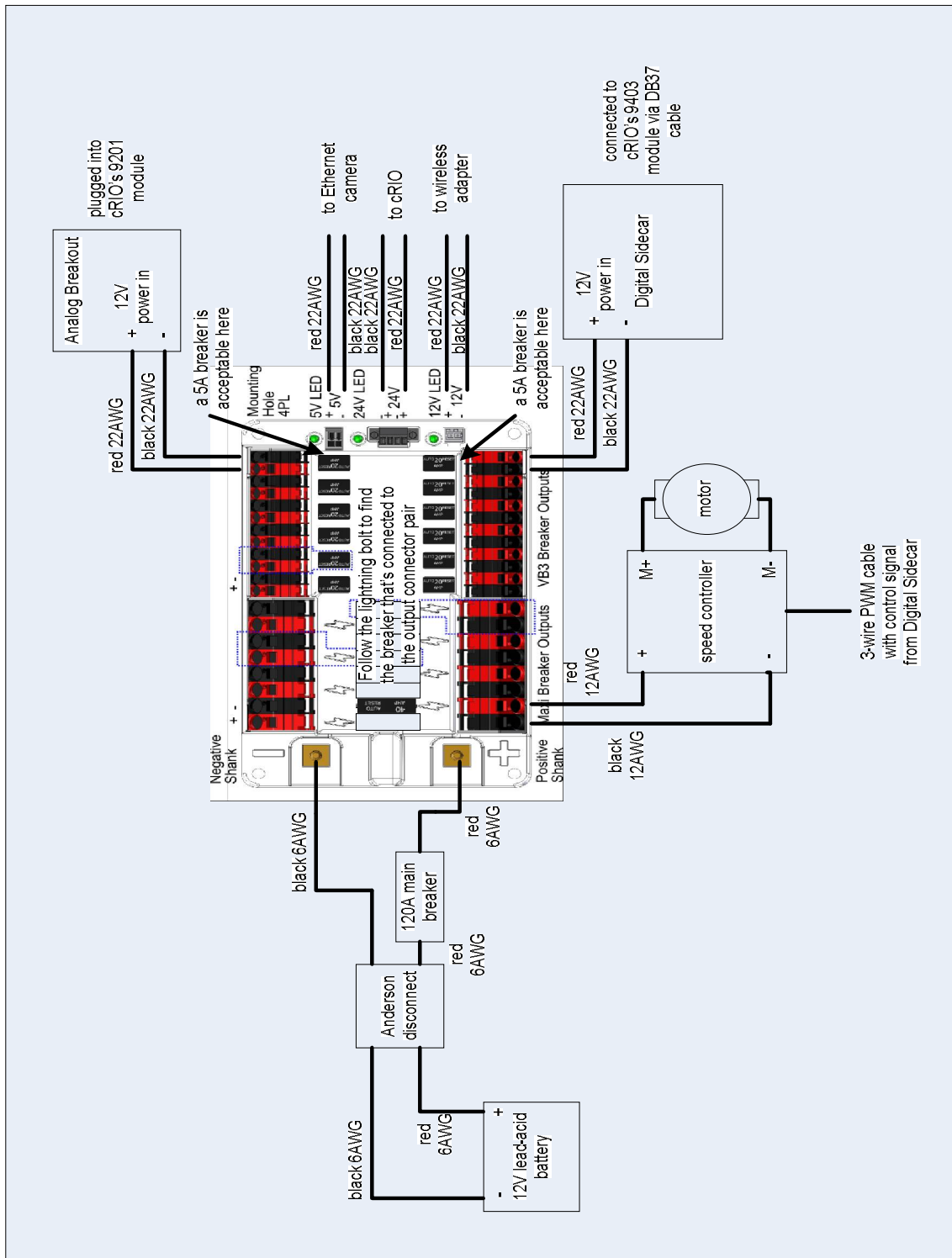

3.1.4 Specifications

24V supply

| Parameter | Min | Nom | Max | Units | Description |
|---|-----|-----|-----|-------|---|
| Input Voltage, Operational | 4.5 | 12 | 15 | V | |
| Input Voltage, Survive | -20 | | 20 | V | limited by TVS and reverse battery protection FET |
| Output Voltage, Unloaded | 23 | 24 | 25 | V | |
| Output Voltage Ripple (pk-pk), Unloaded | | | 1 | V | |
| Output Current Limit, PTC | | 1.1 | 2.2 | A | hold characteristic, this PTC is in the ground return path to the power supply |
| Output Power Limit | | | 20 | W | boost channel protection |
| Input Current Limit | | 15 | | A | input fuse (at the input to the power supply from battery input terminal, the primary purpose of this fuse is to protect from shorts on the PD) |

12V supply

| Parameter | Min | Nom | Max | Units | Description |
|---|-----|-----|-----|-------|---|
| Input Voltage, Operational | 4.5 | 12 | 15 | V | |
| Input Voltage, Survive | -20 | | 20 | V | limited by TVS and reverse battery protection FET |
| Output Voltage, Unloaded | 11 | 12 | 13 | V | for Vbattery < 11 V, for Vin > 11V the power supply output tracks Vbattery |
| Output Voltage Ripple (pk-pk), Unloaded | | | 1 | V | |
| Output Current Limit, PTC | | 2 | 4 | A | hold characteristic, this PTC is in the ground return path to the power supply |
| Output Power Limit | | | 20 | W | boost channel protection |
| Input Current Limit | | 15 | | A | input fuse (at the input to the power supply from battery input terminal, the primary purpose of this fuse is to protect from shorts on the PD) |

5V supply

| Parameter | Min | Nom | Max | Units | Description |
|----------------------------|-----|-----|-----|-------|---|
| Input Voltage, Operational | 5.5 | 12 | 15 | V | |
| Input Voltage, Survive | -20 | | 20 | V | limited by TVS and reverse battery protection FET |
| Under-voltage Lockout | 5.3 | | 5.5 | V | |
| Output Voltage, Unloaded | 4.8 | 5 | 5.2 | V | |
| Ripple (pk-pk), Unloaded | | | 1 | V | |
| | | | | | |
| Continuous Current Limit | | 3 | 4 | A | |

3.1.5 Notes and Warnings

The PD's power input/battery shanks are Metric 6. A ¼" nut WILL strip these nuts. Use M6 nuts for the PD Shanks.

The PD's power input/battery shanks can shear if torqued more than 3.9 Nm. Do not over-tighten. The reverse battery protection only protects the power supplies on the PD (and their attached loads). Applying batteries to the PD with reversed polarity may damage devices attached to the thermal breakers.

Don't panic if the 12V power supply output is a bit higher than 12V. The supply tracks battery voltage when the battery is fully charged and greater than 12V.

When under light load, the 24V boost supply will emit an audible whining noise and have a larger voltage ripple. This is an artifact of its power saving mode, and should not cause concern.

The thermal breaker outputs will read as 12V when the breaker is removed and there is no load. There is a weak (100kOhm) connection to power that is an artifact of the blown breaker LED circuit. It is not cause for concern.

The large 40A-capable Maxi-style breakers are interleaved – follow the lightning bolt to the connector.

The smaller VB3 breakers must be correctly oriented or they will interfere.

When designing the layout of the electronic components, leave enough room to access the WAGO connectors with the WAGO tool.

3.1.6 Troubleshooting and FAQ

What are the part numbers for the mating connectors?

| Connector | manufacturer and P/N for mating connector |
|------------------|---|
| 24V power output | Sauro CTF04BV8-CN |
| 12V power output | WAGO 734-102 |

How do I build a cable for passing 24V power to the cRIO?

- Take a color coded pair of 22-14AWG wire and cut to length
- Optionally twist the pair now for better cable management.
- Strip 5-6mm off of both ends of both wires.
- Use a small flat head screwdriver to actuate the Sauro CTF04BV8-CN connectors
- Insert the positive wire in the port labeled "V"
- Insert the negative wire into the port labeled "C" next to the "V" port.
- Insert into the Sauro CTM040V8. Tighten screws to ~¼Nm.

- Give a smart tug to verify the connection is secure.

How do I build a cable for passing 12V power to the WiFi adapter?

- Take the module's power adapter and cut the wire off a few inches from the Wall-Wart.
- Separate the wires and strip 7mm off the ends.
- To insert wire into a WAGO 734-102 connector, push down on the actuation port in back. Alternatively, use the plastic actuation lever.
- Insert the positive (striped) wire in the right port of the WAGO 734-102 connector. Note: the correct orientation can be verified by looking at the silk screen on the PD Module.
- Insert the negative wire in the left port of the WAGO 734-102 connector.
- Give a smart tug to verify the connection is secure.
- Insert the WAGO 734-102 into the mating connector on the PD.
- Power the PD, and verify that the barrel connector's center conductor is positive.

How do I build a cable for passing 5V power to the Ethernet camera?

- Take the camera's power adapter (PN SA106A-0512-6) and cut the wire off a few inches from the Wall-Wart.
 - Note: There are two power adapters for the camera included in the Kit, one in the camera box and one separate. Use the separate one (PN SA106A-0512-6) to make this adapter.
- Separate the wires and strip 5-6mm off the ends.
- Use a small flat head screwdriver to open the WAGO 739-302.
- Insert the positive (striped) wire in the right port. Note: the correct orientation can be verified by looking at the silk screen on the PD Module.
- Insert the negative wire in the left port.
- Give a smart tug to verify the connection is secure.
- Power the PD, and verify that the barrel connector's center conductor is positive.

How do I operate the large WAGO connectors?

To actuate a 745-85X or 745-83X series connector, gently shove your WAGO tool into the actuation port until it hits a hard stop. Beginning with the tool parallel to the circuit board, push inward and up with the palm of your hand, while pushing down with your finger. The tip of the tool will scrape along the back of the connector and hit a hard stop. The tool can now stand on its own, and the connector's clamp is fully open.

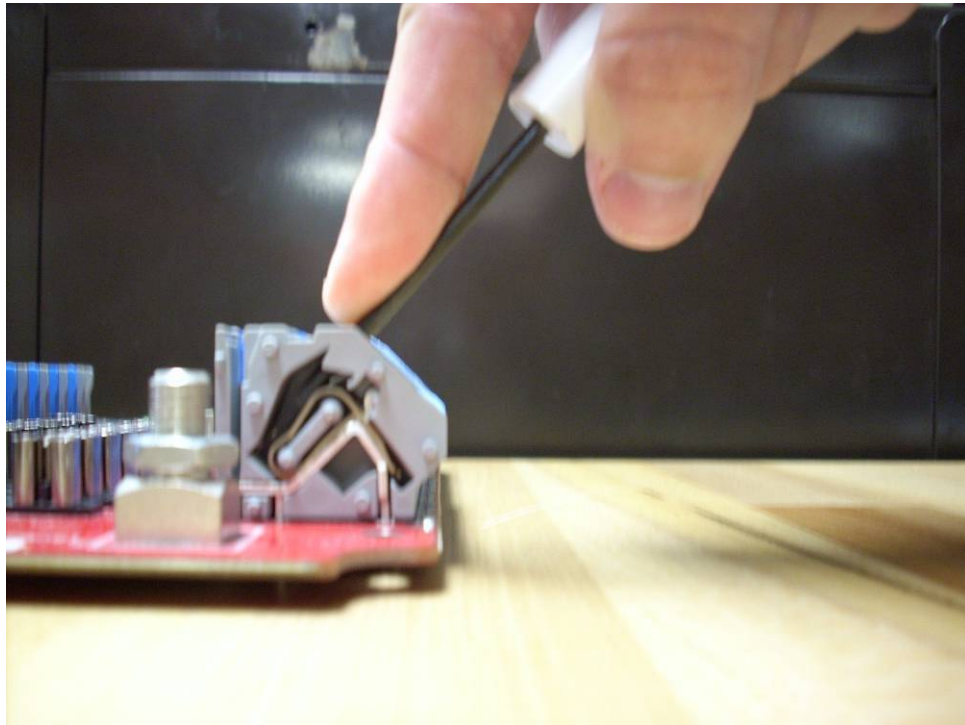

DO NOT attempt to pry the connector open. This will result in frustration. If you require two hands for this, you are probably doing it wrong.

Note: It is possible to “stab” the 745-8XX connector by inserting the tool at too great an attack angle. This may break the plastic tab. This is only aesthetic. Try again with a flatter angle.

3.1.7 Mechanicals

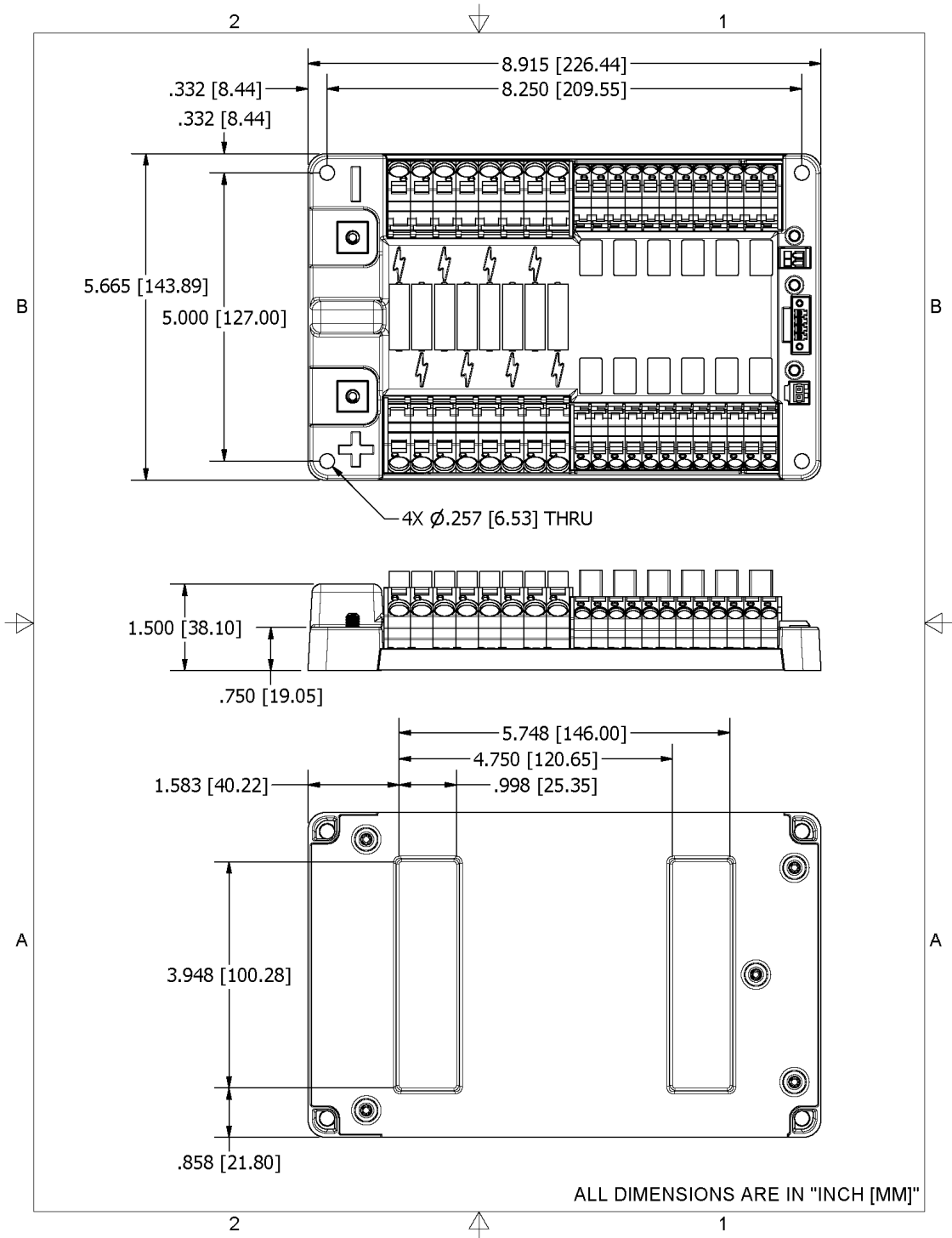

3.2 COMPACT RIO

For the full data sheet please refer to the NI website: <http://decibel.ni.com/content/docs/DOC-2632>

3.3 ANALOG BREAKOUT

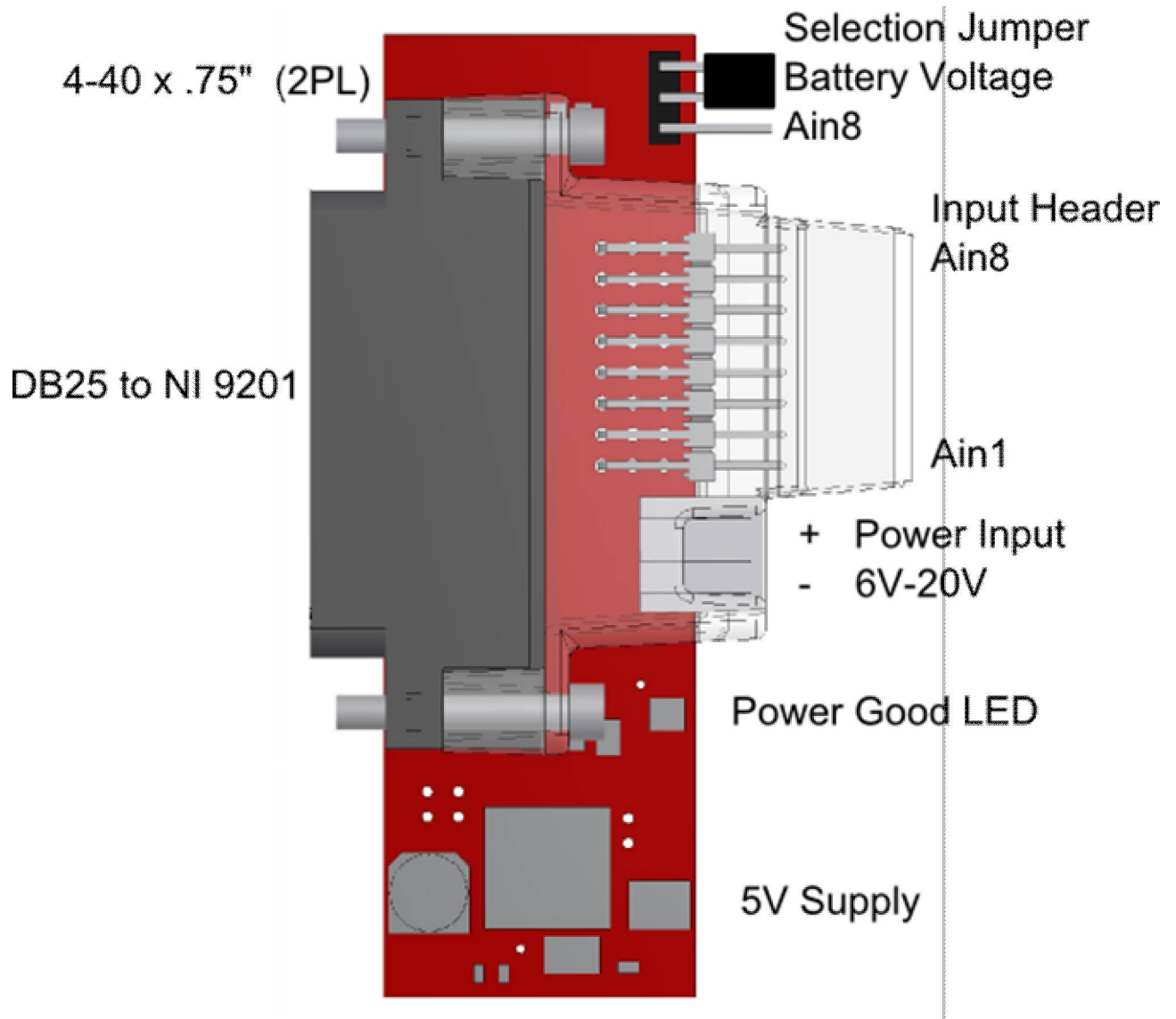
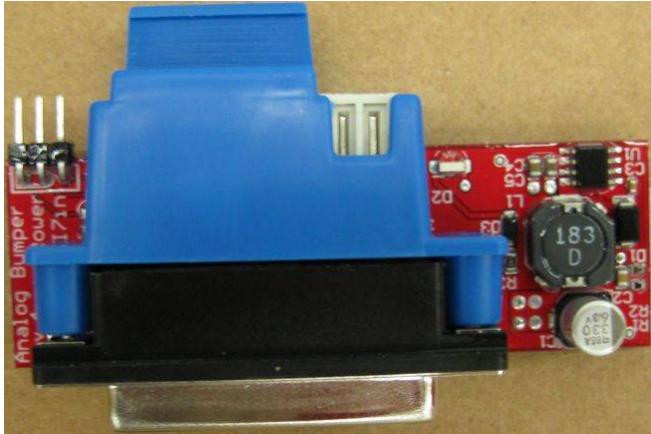

3.3.1 Functional Description

The Analog Breakout is designed to make interfacing with the NI 9201 analog input module easier for FIRST teams. It adapts the DB25 interface to the familiar three row 0.1" pin field and provides a 5V rail to power sensors. The included plastic shroud provides an easy way to lock the connectors.

3.3.1.1 Features

- 5V/0.25A power supply for providing power to analog sensors
- Wide-range power input for tolerating battery voltage variations
- Reverse Battery Protection
- Jumper to optionally connect battery voltage to AI8 for sensing battery/power input status
- Standard 3-pin PWM cable interface (5V, ground and analog input) for sensors with locking feature built into the plastic shroud
- DB25 connector with screw holes for securely mounting to an NI 9201 analog input module
- Per-Channel 1600Hz single pole filters.

3.3.1.2 Pinout

Analog Breakout – side view of connectors

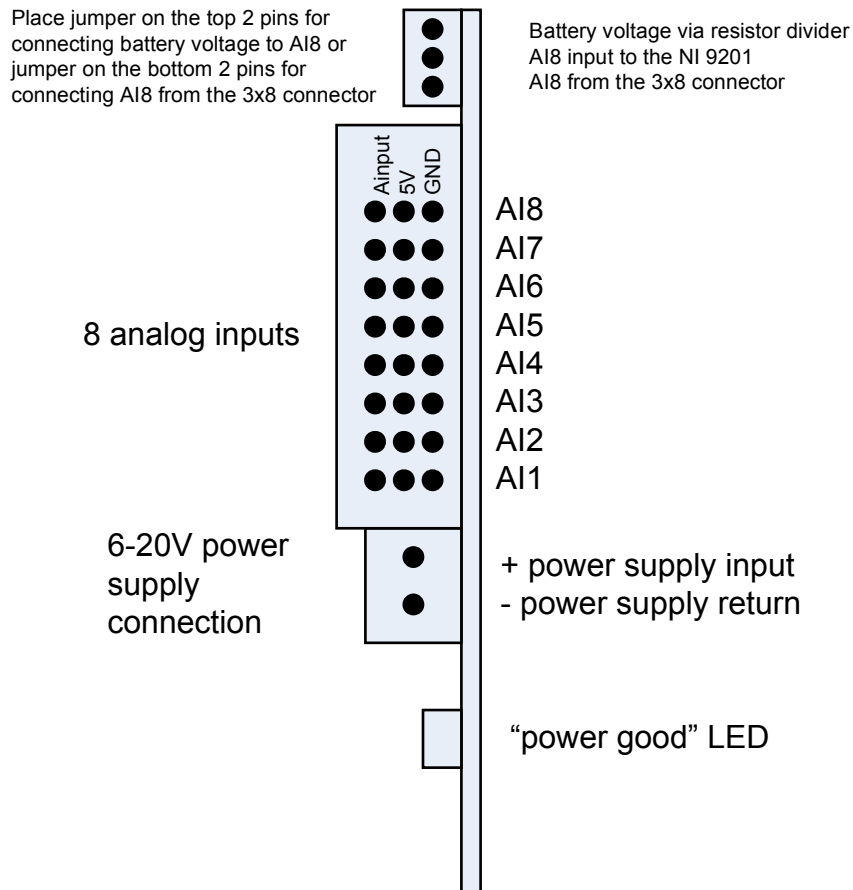

| PCB Reference Designator | Name | Description |
|--------------------------|--------------|--|
| J1 | DB25 | Mates to NI 9201 (with optional cable) |
| J2 | Analog Input | Mates to 8 3-conductor cables |
| J3 | Power Input | 734-162 mates to 734-102 Supplies power to the module |
| J4 | AI8 Select | Accepts 2 conductor Shunt Selects what AI8 is connected to. |
| D2 | Power LED | Lit when power is applied |

3.3.2 Typical Application

** Always refer to FIRST rules for using this module within competition robots. The following sequence describes an example application that may not fully comply with FIRST rules.

- 1) Plug the Analog Breakout module into an NI 9201 analog input module and secure with screws
- 2) apply power to J3 from the PD via 5A breaker and smaller WAGOs
- 3) select whether AI8 is to be connected to the 3x8 header or input power for battery sensing and apply jumper accordingly
- 4) attach sensors via 3-pin PWM to the 3x8 header with careful consideration of polarity

3.3.3 Specifications

| Parameter | Min | Nom | Max | Units | Description |
|-----------------|-------|-------|------|-------|---|
| Vin Survive | -20 | | 20 | Volts | Survivable voltage on J3 |
| Vin Operational | 5.6 | 12 | 15 | Volts | Acceptable voltage on J3 for normal operation |
| Vout | 4.9 | 5 | 5.1 | Volts | Output Voltage of linear supply. |
| Iout Total | | | 0.25 | Amps | Output Current of linear supply |
| Iout / Channel | | | .25 | Amps | Output Current per pin |
| AI Voltage | -10 | | 10 | Volts | Input on any AI pin on J2 (from 9201) |
| AI8 Divider | 0.590 | 0.595 | 0.6 | | |

3.3.4 Troubleshooting and FAQ

How do I build a cable for passing 12V power to the Analog Breakout?

- Take a color coded pair of 22AWG or better wire and cut to length
- Optionally twist the pair now for better cable management.
- Strip 7mm off the ends.
- To insert wire into a WAGO 734-102 connector, push down on the actuation port in back with a screw driver, or use an actuation lever.
- Insert the positive wire in the right port of the WAGO 734-102 connector. Note: the correct orientation can be verified by looking at the silk screen on the Analog Breakout
- Insert the negative wire in the left port of the WAGO 734-102 connector.
- Give a smart tug to verify the connection is secure.
- Verify proper polarity. Plug the new cable into a Solenoid Breakout. If the green LED lights, the cable is correct.
- Insert the WAGO 734-102 into the mating connector on the Breakout.

How do I measure the battery voltage using the Analog Breakout?

- Use a shunt (jumper) to connect the outer two pins of the "AI8 Select" connector

- Battery voltage is reduced to ~40% of its actual value by a 680/1k voltage divider and filtered by a 0.1uF capacitor.

-

Why isn't AI8 working?

- Use a shunt (jumper) to connect the inner two pins of the "AI8 Select" connector

My sensors don't work, and D2 isn't lit. Why?

- Check with a multi-meter to see if you are getting power onto J3. Is a breaker missing?
- The Analog Breakout is not protected from reversed polarity on J3. Did you wire it backwards? You may need to replace the module.

How do I connect a potentiometer?

- Connect the wiper to the input pin – Top row.
- Connect the other two pins to +5 and ground – Middle and bottom rows.

My sensor draws more than 0.25A. Can I use it?

- The circuit can source burst currents up to 1.0A, but steady state dissipation is limited by power dissipation.
- If you need higher steady state current, please use a 2009 Analog Breakout.

Note: the supply will thermal shut down if overused. No damage will occur, but it could shut down in the middle of a match. If you want to try pushing the envelope, install a jumper on one of the analog channels so that you are monitoring the power supply.

3.3.5 Mechanicals

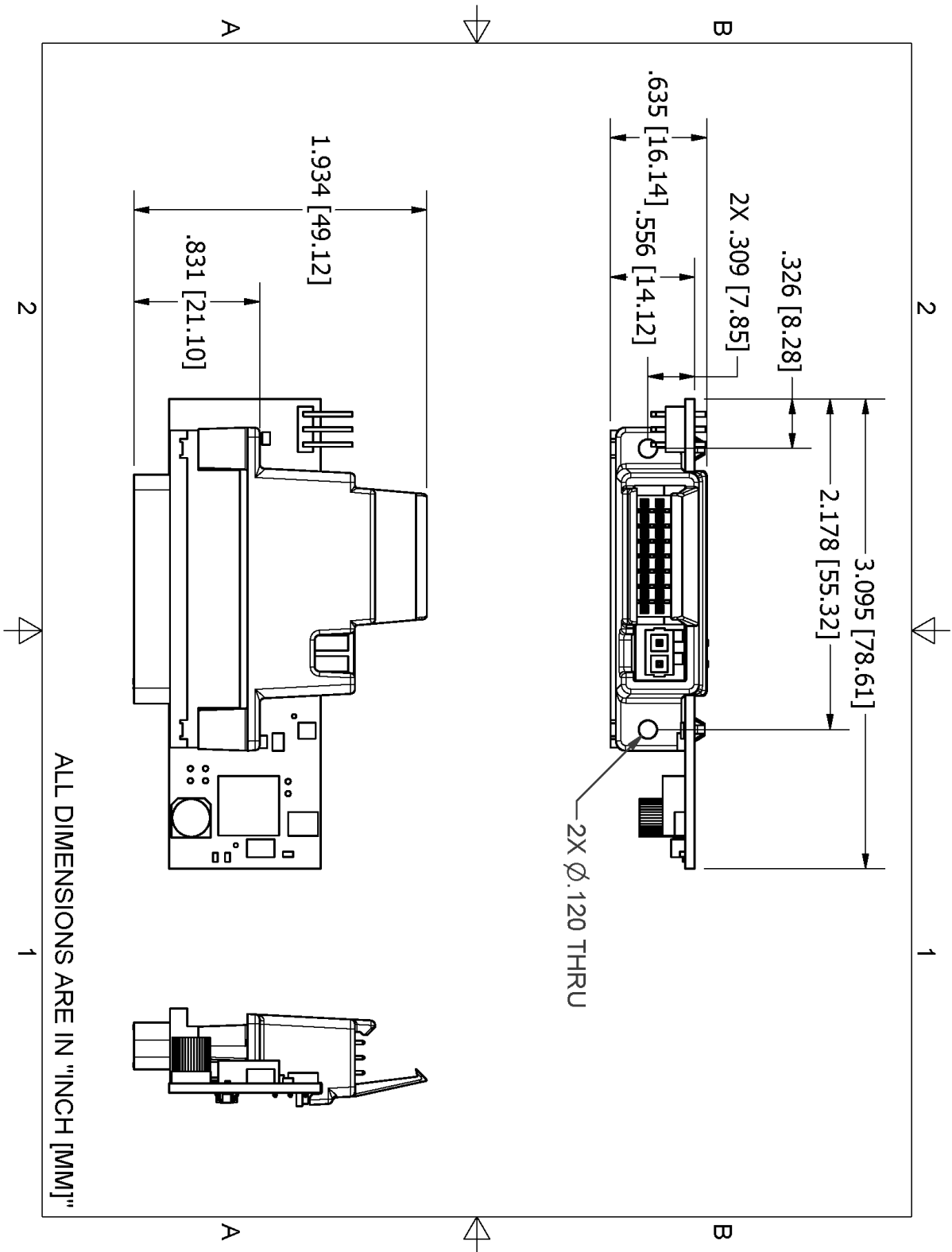

3.4 DIGITAL SIDECAR

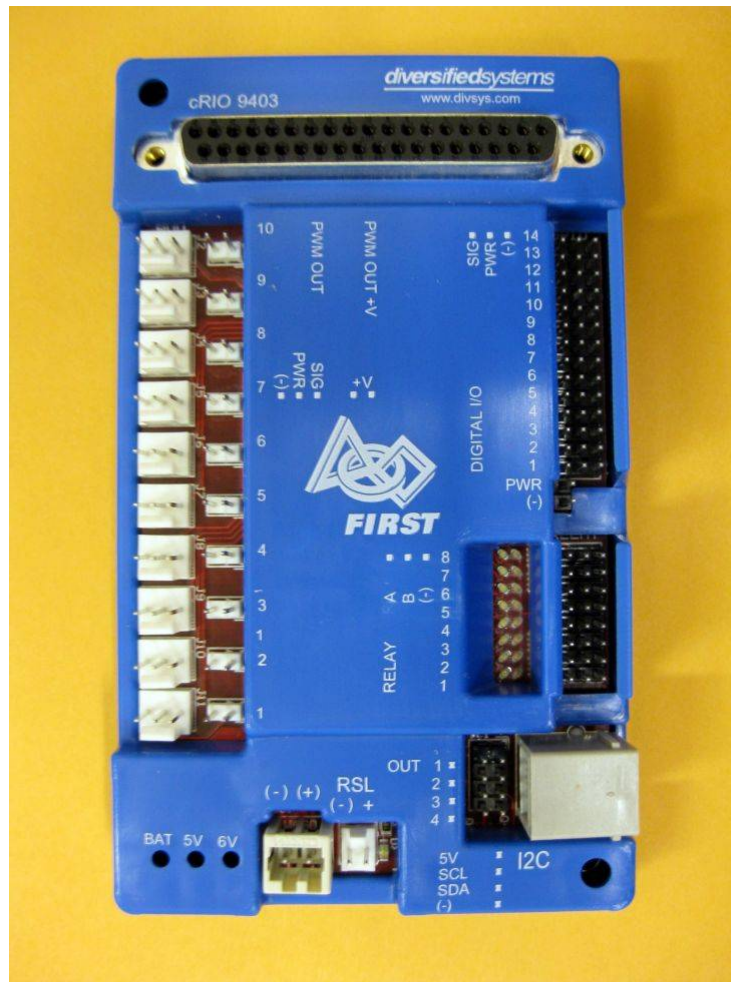

3.4.1 Functional Description

The Digital Sidecar is a breakout module that is designed to adapt a single cRIO 9403 32-channel digital I/O module into a set of I/O that is familiar to robotics hobbyists.

3.4.1.1 Features

The Digital Sidecar includes the following features:

- 10 PWM outputs for driving speed controllers such as IFI Victors and Luminary Jaguars and servos such as the Hitec HS322HD
- 14 general purpose I/O (aka GPIO) lines with available 5V power for each
- 16 relay outputs (8 FORWARD and 8 REVERSE outputs) for driving relay controllers such as an IFI Spike
- I2C headers – one 2x4 pin header and one connector that is compatible with I2C-based Lego NXT accessories
- Robot Signal Light header for a robot status indicator
- 6V/3A buck power supply to power servos attached to the PWM outputs (with individual jumpers for each PWM output to select application of power)
- 5V/3A buck power supply for DSC circuitry with excess power available at the GPIO and I2C headers
- Extra 5V and ground connections adjacent to GPIO1 for using a single row-header to create a SPI interface (typically using GPIO1-4 for MOSI, MISO, SCLK and CS in addition to the supporting 5V and ground connections)
- Reverse-battery protection to prevent damage due to accidental reversal of applied power
- Power is derived from a nominal 12V supply

- DB37 connector for attachment to a cRIO 9403 32-channel digital I/O module

3.4.1.2 Pinout

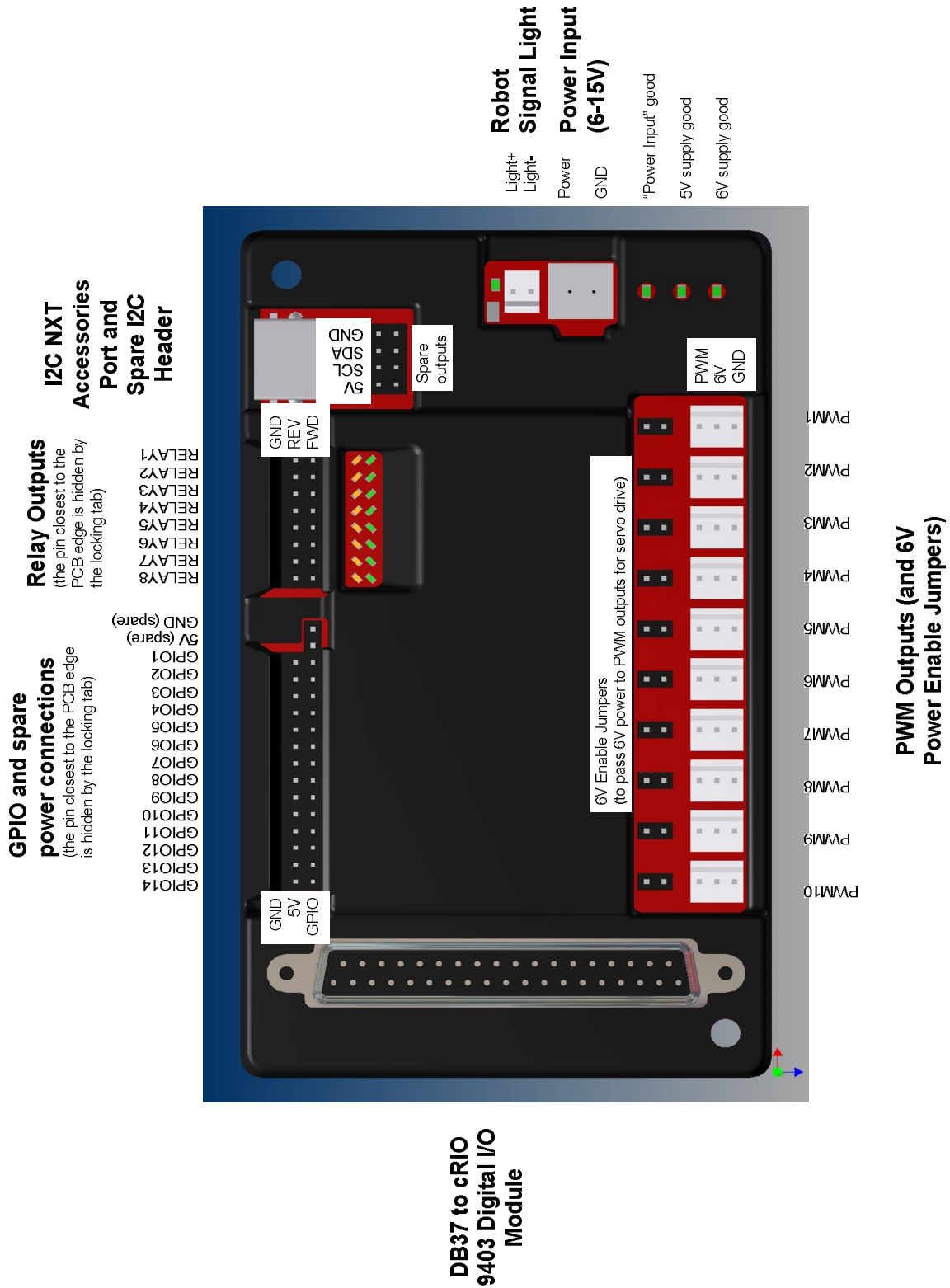

| PCB Reference Designator | Name | Description |
|--------------------------|--------------------|---|
| J1 | cRIO connector | A 37-line DB37 female connector for attaching the module to a cRIO 9403 32-channel digital I/O module (typically via ribbon or shielded cable) |
| J2-J11 | PWM10..PWM1 | PWM outputs for controlling speed controllers and servos. The header is a Molex P/N 22-23-2031 (or similar) with a friction locking feature which accepts any standard PWM cable in addition to many 0.1" spacing headers. The center pin is selectable for providing 6V power via adjacent jumper. The pin closest to the PCB's edge is ground. The pin furthest from the PCB's edge is the PWM output signal. |
| J12-J21 | PWMx 6V Enable | Install an 0.1" jumper on these headers to provide 6V power on the adjacent PWM output. ONLY INSTALL A JUMPER WHEN ATTEMPTING TO POWER SERVOS SUCH AS A HITEC HS322HD. SPEED CONTROLLERS ATTACHED TO THE PWM OUTPUTS MAY BE DAMAGED IF THE DSC ATTEMPTS TO PROVIDE 6V POWER ON THE CENTER PIN. |
| J22 | Power Input | Nominal 12V power input via WAGO 734-132. WAGO 734-102 is the typical mating connector with wire size between 14 and 20 AWG. |
| J23 | Robot Signal Light | A 2-pin Molex P/N 22-23-2021 header for providing power to an indicator light. |
| J24 | I2C and spare I/O | A 2x4 set of 0.1" pins with I2C, 5V, ground and 4 spare outputs. |
| J25 | NXT I2C Header | A Lego NXT-compatible I2C header for use with NXT-compatible I2C accessories. |
| J26 | GPIO | A 3x14 0.1" pin field for general purpose digital I/O with 5V available on the center pin, ground on the pin closest to the PCB's edge and I/O signal on the pin furthest from the PCB's edge. |
| J27 | Extra 5V Header | An extra pair of 0.1" pins for providing power and ground adjacent to GPIO1 (typically for creating a SPI-compatible interface using GPIO1-4 for MOSI, MISO, SCLK and CS) |
| J28 | Relay Outputs | A 3x8 0.1" pin field for driving relay modules. The pin closest to the PCB edge is ground, the center pin is REVERSE and the furthest pin is FORWARD. |

3.4.2 Typical Application

** Always refer to FIRST rules for using this module in competition robots. The following sequence describes an example application that may not fully comply with FIRST rules.

- 1) apply power to the DSC via J22 from a 5A (or larger) breaker on the PD
- 2) connect to a cRIO 9403 via 37-channel ribbon cable
- 3) attach servos (eg Hitec HS322HD) to the PWM Outputs and place a corresponding jumper on the 6V Enable header for the PWM Outputs
- 4) attach speed controllers to the PWM Outputs (NO JUMPER FOR 6V ENABLE!)
- 5) attach relay modules to the Relay Outputs
- 6) attach a Robot Signal Light to the header
- 7) attach I2C-compatible NXT accessories to the NXT port
- 8) attach devices to the GPIO headers

3.4.3 Specifications

General

| Parameter | Min | Nom | Max | Units | Description |
|------------------------------|-----|------|-----|----------------------|--|
| PWM Output - Current | | | 15 | mA (source and sink) | There are 330 Ohm series resistors in each output's path. The outputs are buffered using a 74AC244 and a 74LVC2G125 with a 5V supply. |
| Relay Output - Current | | | 7.5 | mA (source and sink) | There are 680 Ohm series resistors in each output's path. The outputs are buffered using a pair of 74LV595s with a 5V supply. |
| GPIO – Pull-Ups | | 10 | | kOhms | these signals are passed directly to the NI 9403 module without any series resistance but include pull-ups to 5V |
| I2C Pull-Ups | | 3.16 | | kOhms | Pull-ups to 5V supply (included on the DSC) for I2C signals |
| Robot Signal Light - Voltage | | Vin | | | The Robot Signal Light is powered by the same voltage as passed to the DSC via power input connection |
| Robot Signal Light – Current | | 1.1 | 2.2 | Amps | Determined by a PTC for current-limiting, There is a snubber diode in parallel with the output header for protection from any load inductance. |

6V supply

| Parameter | Min | Nom | Max | Units | Description |
|----------------------------|-----|-----|-----|-------|---|
| Input Voltage, Operational | 6.7 | 12 | 15 | V | |
| Input Voltage, Survive | -25 | | 25 | V | limited by reverse battery protection FET |
| Undervoltage Lockout | 6.3 | | 6.5 | V | |
| Output Voltage, Unloaded | 5.8 | 6 | 6.2 | V | |
| Ripple (pk-pk), 2A load | | 22 | 100 | mV | |
| Per Cycle Current Limit | 4 | 5 | 6 | A | |
| Continuous Current Limit | | 3 | 4 | A | |

5V supply

| Parameter | Min | Nom | Max | Units | Description |
|----------------------------|-----|-----|-----|-------|---|
| Input Voltage, Operational | 5.5 | 12 | 15 | V | |
| Input Voltage, Survive | -25 | | 25 | V | limited by reverse battery protection FET |
| Undervoltage Lockout | 5.3 | | 5.5 | V | |
| Output Voltage, Unloaded | 4.8 | 5 | 5.2 | V | |
| Ripple (pk-pk), 2A load | | 21 | 100 | mV | |
| Per Cycle Current Limit | 4 | 5 | 6 | A | |
| Continuous Current Limit | | 3 | 4 | A | |

3.4.4 Warnings

Only install the jumpers for applying 6V power to the PWM Output headers for connecting to servos such as a Hitec HS322HD. If the jumper is installed and the PWM Output is used to drive a speed controller, the application of 6V power could damage the speed controller and/or DSC.

3.4.5 Troubleshooting and FAQ

Either or both of the power supply LEDs are out, but the power-in LED is on. Why?

- Both of these supplies are internally protected against short circuits. It is possible to short one without affecting the other, which may explain why one is not working.
- Power off your robot – the offending element may be hot.
- Examine your wiring and your module carefully for the short.

Why isn't my servo motor moving?

- Check to make sure that the PWM channel's 6V selection jumper is inserted.
- Check the 6V supply LED.

The PWM connectors have a locking tab. How do I use them?

- They are [Molex 22-23-2031 KK vertical friction locks](#).
- You may use the same cables you have always used – The locking tab won't get in your way, and does add a small bit of friction to the connection.
- For added security, use a Molex 2695, 6471, 7880, 4455 or 7720 series connector. Our favorite is the [0022013037](#)

How do I build a cable for passing 12V power to the Digital Sidecar?

- Take a color coded pair of 22AWG or better wire and cut to length
- Optionally twist the pair now for better cable management.
- Strip 7mm off the ends.
- To insert wire into a WAGO 734-102 connector, push down on the actuation port in back with a screw driver, or use an actuation lever.
- Insert the positive wire in the right port of the WAGO 734-102 connector. Note: the correct orientation can be verified by looking at the silk screen on the Digital Sidecar.
- Insert the negative wire in the left port of the WAGO 734-102 connector.
- Give a smart tug to verify the connection is secure.
- Insert the WAGO 734-102 into the mating connector on the Digital Sidecar.

3.4.6 Mechanicals

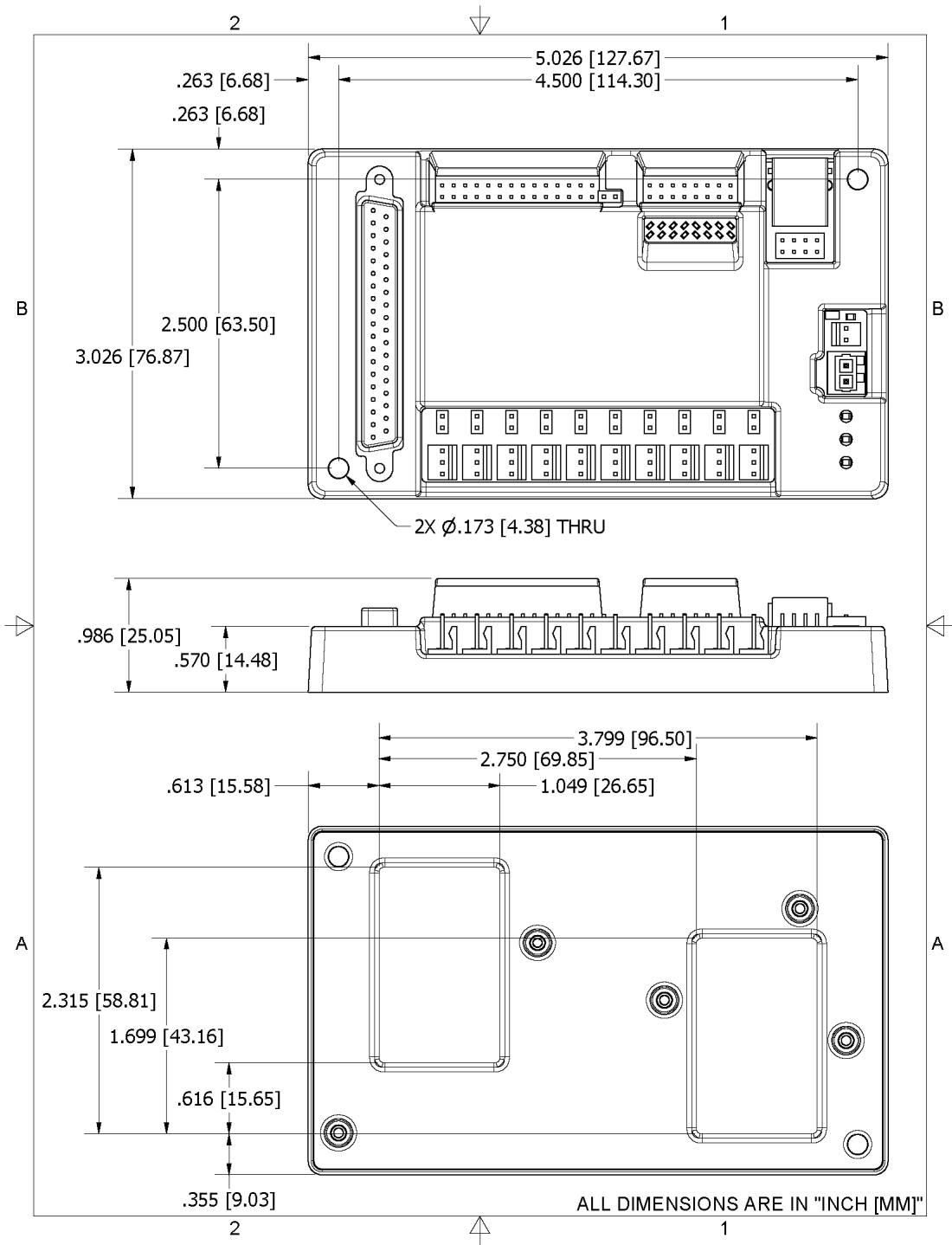

3.5 SOLENOID BREAKOUT

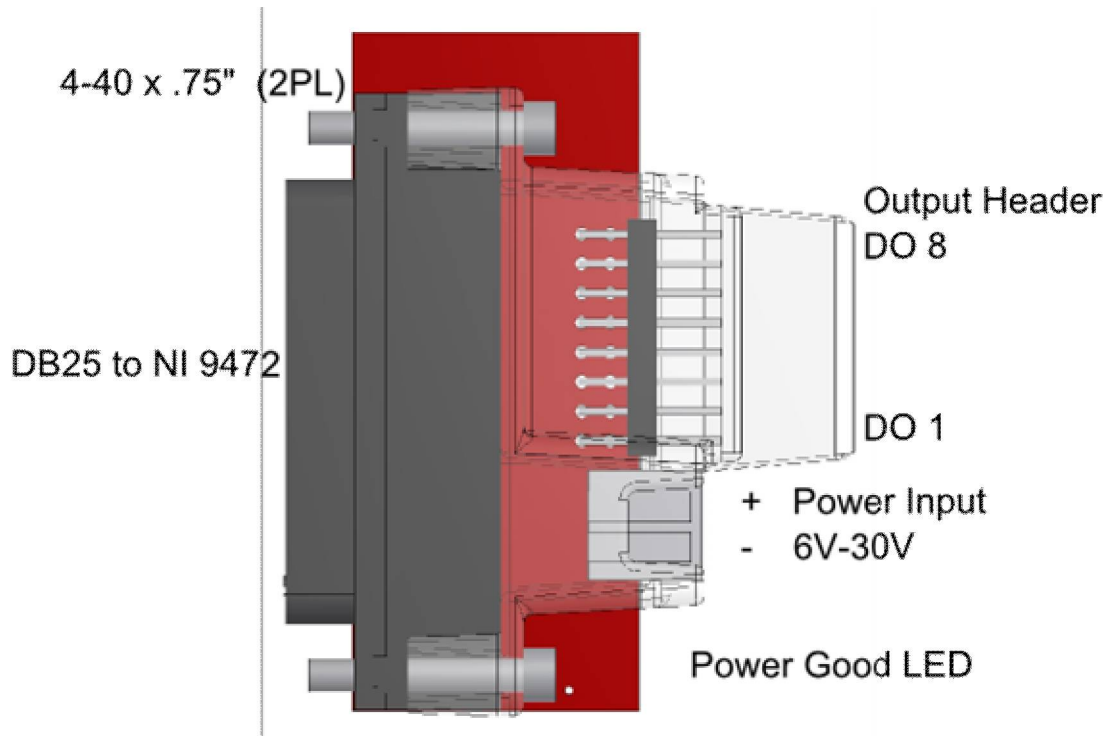
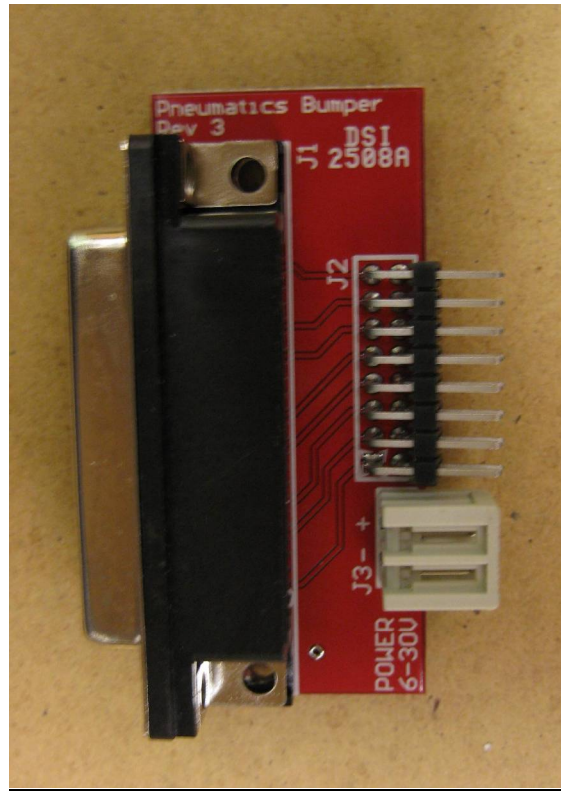

3.5.1 Functional Description

The Solenoid Breakout is designed to make interfacing with the NI 9472 Digital Sourcing Module easier for FIRST teams. It adapts the DB25 interface to the familiar two row 0.1" pin field. The included plastic shroud provides an easy way to lock the connectors.

3.5.1.1 Features

- Wide-range power input provided by the NI 9472
- 2-pin cable interface (switched power output and ground) for attaching loads with locking feature built into the plastic shroud
- DB25 connector with screw holes for securely mounting to an NI 9472 output module
- Reverse-voltage protection to avoid damage due to accidental reversal of applied power

3.5.1.2 Pinout

Solenoid Breakout – side view of connectors

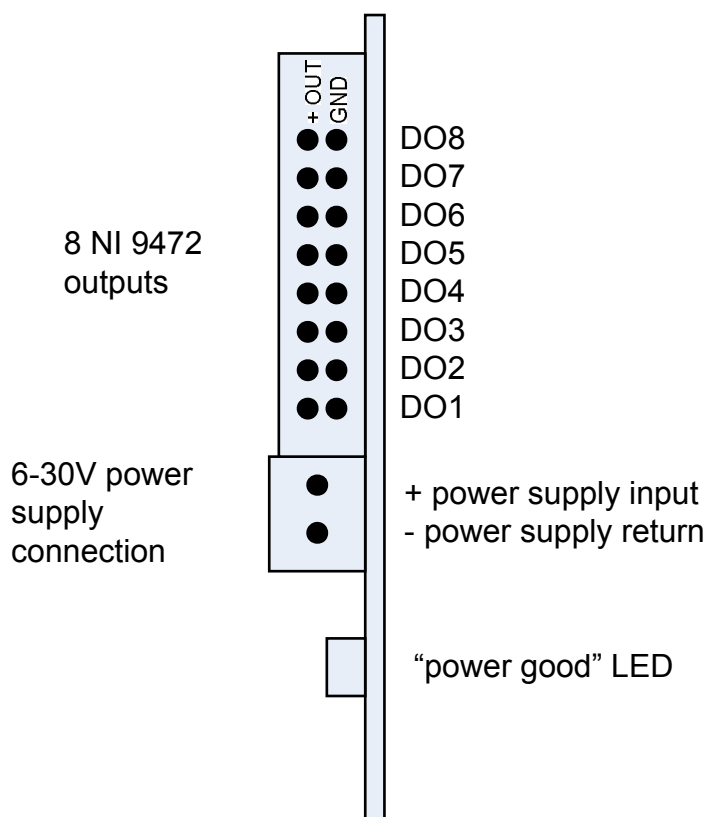

| PCB Reference Designator | Name | Description |
|--------------------------|-----------------|---------------------------------------|
| J1 | DB25 | Mates to NI9472 (with optional cable) |
| J2 | Digital Outputs | Mates to 2 conductor cables |
| J3 | Power In | 734-162 mates with 734-102 |
| D1 | Power LED | Lights when power is properly applied |

3.5.2 Typical Application

** Always refer to FIRST rules for using this module in competition robots. The following sequence describes an example application that may not fully comply with FIRST rules.

- 1) secure the Solenoid Breakout to an NI 9472 using screws
- 2) apply power to J3 from the PD via 5A breaker and smaller WAGOs
- 3) attach loads via 2-pin connectors to the 2x8 header with careful consideration of polarity

3.5.3 Specifications

| Parameter | Min | Nom | Max | Units | Description |
|-----------------|-----|-----|------|-------|------------------------------------|
| Vin Survive | -30 | | 30 | Volts | Survivable voltage on J3 |
| Vin Operational | 6 | 12 | 30 | Volts | Voltage on J3 for normal operation |
| Iout / Channel | | | 0.75 | Amps | Output Current per Channel |

3.5.4 Troubleshooting and FAQ

How do I build a cable for passing 12V power to the Solenoid Breakout?

- Take a color coded pair of 18AWG or better wire and cut to length
- Optionally twist the pair now for better cable management.
- Strip 7mm off the ends.
- To insert wire into a WAGO 734-102 connector, push down on the actuation port in back with a screw driver, or use an actuation lever.
- Insert the positive wire in the right port of the WAGO 734-102 connector. Note: the correct orientation can be verified by looking at the silk screen on the Solenoid Breakout.
- Insert the negative wire in the left port of the WAGO 734-102 connector.
- Give a smart tug to verify the connection is secure.
- Insert the WAGO 734-102 into the mating connector on the Breakout.

I have a load that takes more than 0.75A. May I use it?

- Check the FRC robot rules to ensure that your device is game legal.
- You can use several outputs together, such that each one sources up to 0.75A. Be sure to common them in the wiring (positive and negative) AND in the software.

3.5.5 Mechanical

